

Cu terminals and connectors 0.75 - 1000 mm²

General information	2
Tube terminals 0.75 - 10 mm²	4
Tube terminals 16 - 800 mm², KRF, and 500 - 1000 mm², KRD	5
Tube terminals 10 - 1000 mm², KRT	7
Tube terminals 16 - 1000 mm², KRD	9
Cu terminals 50 - 240 mm², KRFN, with narrow palm	10
Tube terminals with two stud holes 35 - 400 mm², KRF	11
Tube terminals 45°, 10 - 150 mm², KRF	12
Tube terminals 45°, 10 - 120 mm², KRT	13
Tube terminals 90° degrees 10 - 150 mm², KRF	14
Tube terminals 90° degrees 10 - 120 mm², KRT	15
Tube terminals 10 - 300 mm² DIN 46235	16
Sheet metal terminals 10 - 240 mm² DIN 46234	17
Through connectors 0,75 - 800 mm², KS/KSF	18
Through connectors 10 - 800 mm², KST	19
Through connectors 16 - 800 mm², KSD	19
Through connectors with partition 10 - 400 mm²	20
Parallel connectors for total cross section areas 0.5 - 7.5 mm²	20
Connectors for solid Cu conductors 6 - 16 mm²	20
Pin terminals 10 - 95 mm² DIN 46230	21
Connectors for Ericsson Cables Excel and Fxcel type 10 - 16 mm²	21
Branch connectors (C-sleeves) 6 - 300 mm²	22
Application table for C-sleeves (side feed only)	23

General information about Cu terminals

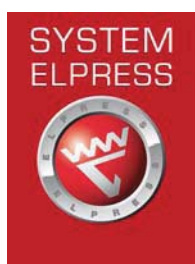

System Elpress

System Elpress consists of connectors and tools tested together for optimum connection result. The System concept makes you as a customer able to feel secure when using our system and to be sure a safe connection is made when Elpress products are used correctly.

Cu-connections

Elpress Cu-connections are produced from electrolytic 99.9% copper. Terminals and through connectors exist in a large variety of types for stranded as well as for flexible conductors. C-sleeves for earth conductor branch off also come in a large number of sizes. If a standard type is not suitable, we produce tailor made designs specific to the application.

KR/KRF terminals and **KS/KSF** connectors may be used for both stranded and flexible conductors.

KRD terminals and **KSD** connectors are used for stranded conductors.

KRT terminals and **KST** connectors equal the German "Standard types" (not DIN!) and are used for stranded conductors.

C-sleeves are used for branch-off or cross connections for mainly earth conductors such as for lightning protection and earthing grids.

By crimping Elpress terminals and connectors with Elpress crimp tools, connections are achieved that meet the requirements of SEN 245010, BS 4579:1, VDE 0220:1, EN-IEC 61238:1 whichever is applicable.



UL approved terminals

UL is an American standard which is also internationally accepted. Elpress standard Cu terminals of types **KR/KS**, **KRF/KSF** and **KRT/KST**, are UL approved according to no. E205350. Cu terminals of types

KR/KS, **KRF/KSF** are for stranded and flexible copper wires, classes 2 and 5 according to IEC 60228, and have a working area of 1-500 mm².

Cu terminals of types **KRT/KST** is used for stranded copper wires 10-500 mm².



DNV approved

Elpress **KRF/KSF**, **KRT/KST** terminals comply with DNV's rules for the classification of ships and Det Norske Veritas' Offshore Standards. The terminals are approved for installations on ships and mobile offshore units.

Number of crimps

Normally only one crimp per conductor end is needed up to and including 150 mm² and two crimps for larger areas. For detailed information reg no. of crimps, see tables for dies/tools. If possible multiple crimps should be positioned with a few mm distance from each other and from the neck end. In many cases however, overlapping crimps have to be made for space reasons.

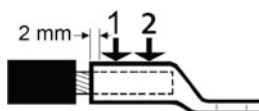

Crimp sequence with two adjacent crimps.

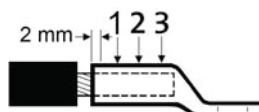

Crimp sequence with three adjacent crimps.

Markings on Cu-connections

Elpress marking system for Cu-connectors shows logotype, conductor area and ID-number for crimp die to be used. This system enables final inspection of proper die use as the die number is automatically imprinted by the die on the crimped barrel.



Marking of tube terminals
32 (on the terminal neck)
ID-no. for the hexagonal die
(Elpress logo) 300-16F (on the palm)
300 = Cu-conductor area, mm ²
16 = hole for screw M16
F = KRF



Marking of connectors
(Elpress logo) 27
ID-no. for hexagonal die
185 F (possible screen area and an earth-sign)
185 = Cu-conductor area, mm ²
F = KSF



Marking of tap-off C-sleeves
120 - 150/70 - 95
120 - 150 = Cu-wire range, mm ²
70 - 95 = Cu-wire range, mm ²
(Elpress logotype) C16 - 13 Cat.no.

Stud holes in terminal palms

Screw-dimension	Hole diameter tolerance H13 (Ø mm)
M 3	3,2
M 4	4,3
M 5	5,3
M 6	6,4
M 8	8,4
M 10	10,5
M 12	13
M 16	17
M 20	21
M 24	25

Screws and washers

The following apply to bright galvanized nuts and screws in strength class 8.8 used for connecting terminals to Cu and Al bus bars:

- Always use a torque wrench to ensure that they are tightened to the right torque. Ensure it is regularly calibrated in accordance with the supplier's instructions.
- Use the recommended torque in accordance with the screw manufacturer's instructions.
- Always use a hard flat washer to reduce friction between the installation surface and hole edge pressure, min hardness HB200.
- A spring washer in accordance with DIN 6796 may be used together with a flat washer to further increase strength in advanced applications.
- Assemble as shown in image.

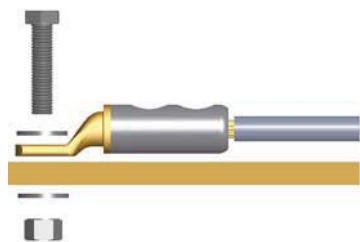

Screw	Tightening torque (Nm)
M5	5
M6	9
M8	21
M10	41
M12	70
M14	110
M16	170
M20	340

EasyGuide

- to easily insert flexible conductors into the terminal

EasyGuide consists of a stand (EG-TS) and tapered inserts (EG-xx) which are chosen to fit the terminal size. Place the terminal in the guiding groove on one side of the insert and introduce the conductor from the other side, open the insert halves and remove the terminal with the conductor in place.

Finally a simple way to get all the strands into the barrel! Suits Elpress type - KRF terminals and connectors from 6 to 240 mm².

Inserts	
6 mm ²	EG 6
10 mm ²	EG 10
16 mm ²	EG 16
25 mm ²	EG 25
35 mm ²	EG 35
50 mm ²	EG 50
70 mm ²	EG 70
95 mm ²	EG 95
120 mm ²	EG 120
150 mm ²	EG 150
185 mm ²	EG 185
240 mm ²	EG 240



EasyGuide.



Customized products

A customized product is an important part of our work. It is a special challenge to solve problems for customers while producing products profitably. In this way, we also have our knowledge of customer needs. Among these connectors include different models of T-connectors where you can connect three conductors

of the same size by using only one connection. These are used for example in transformer manufacturing. Other connections in the transformer manufacturing is the terminal for tap changers and lead-through terminals. In summary, all connections are designed to be an easy way to ensure a high quality crimped connection even in advanced applications.

Cu terminals and connectors 0.75 - 1000 mm²

Tube terminals 0.75 - 10 mm²

- Data: Cu 99.95%, tin plated
- Cable inspection hole, for flexible (class 5) and stranded (class 2) Cu-conductors.
- UL-approved (1-10 mm²).

Marking example KR: 10 10

10 = mm² 10 = palm hole for M10



AWG	mm ²	Cat. no.	Screw	mm W	d	t	L	s	Pcs/ pack	Rec. tool
(22)-18	0,75	KR0,75-3*	M3	6,0	1,3	0,8	16,0	7	100	DKB0760
(22)-18		KR0,75-4*	M4	6,0	1,3	0,8	17,0	7	100	DKB0760
(18)-16	1,5	KR1,5-3*	M3	6,5	1,8	1,0	16,0	7	100	DKB0760
(18)-16		KR1,5-4*	M4	6,5	1,8	1,0	17,0	7	100	DKB0760
(18)-16		KR1,5-5*	M5	7,5	1,8	0,8	18,0	7	100	DKB0760
(16)-14	2,5	KR2,5-3*	M3	7,5	2,3	1,3	17,0	8	100	DKB0760
(16)-14		KR2,5-4*	M4	7,5	2,3	1,3	18,0	8	100	DKB0760
(16)-14		KR2,5-5*	M5	8,5	2,3	1,2	19,0	8	100	DKB0760
(16)-14		KR2,5-6*	M6	8,5	2,3	1,1	19,0	8	100	DKB0760
12	4	KR4-4	M4	8,5	3,0	1,5	21	9	100	GWB4099, ES2258
12		KR4-5	M5	9,0	3,0	1,5	22	9	100	GWB4099, ES2258
12		KR4-6	M6	10,0	3,0	1,4	23	9	100	GWB4099, ES2258
10	6	KR6-4	M4	9,5	4,0	1,7	22	9	100	GWB4099, ES2258
10		KR6-5	M5	9,5	4,0	1,7	22	9	100	GWB4099, ES2258
10		KR6-6	M6	10,0	4,0	1,6	23	9	100	GWB4099, ES2258
10		KR6-8	M8	13,0	4,0	1,2	30	9	100	GWB4099, ES2258
8	10	KR10-5	M5	11,5	5,0	3,0	29	11	100	GWB4099, ES2258
8		KR10-6	M6	11,5	5,0	3,0	29	11	100	GWB4099, ES2258
8		KR10-8	M8	13,5	5,0	2,2	33	11	100	GWB4099, ES2258
8		KR10-10	M10	16,0	5,0	2,0	34	11	100	GWB4099, ES2258
8		KR10-12	M12	19,0	5,0	1,7	41	11	100	GWB4099, ES2258

t = palm thickness s = strip length
 * without inspection hole

For detailed information regarding recommended tool or system, see chapter 6.

Tube terminals 16 - 800 mm², KRF, and 500 - 1000 mm², KR D

- Data: electrolytic copper, tin plated.
- Cable inspection hole, for stranded (class 2) and flexible (class 5) Cu-conductors.
- UL-approved (KRF 16-500 mm²). DNV-approved (KRF 16-400 mm²).

Marking example KRF: 70 10F, KR D: 500 16 (Elpress logotype included)

70 = mm² 10 = palm hole for M10 F = type KRF, for stranded and flexible conductors
 500 = mm² 16 = palm hole for M16

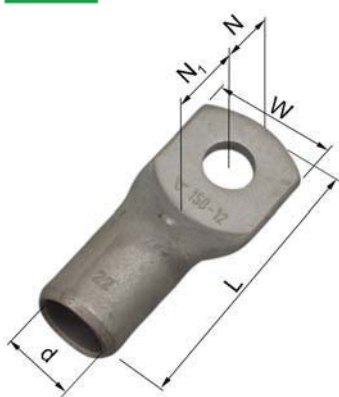

AWG	Cat. no. mm ² - bolt hole M	mm W	d	N	N ₁	L	Pcs/ pack	Die no.	Rec. tool
6	KRF16-6	13,0	6,0	8,0	9,0	34	100	9	V600, V1300
6	KRF16-8	13,0	6,0	8,0	9,0	34	100	9	V600, V1300
6	KRF16-10	16,0	6,0	10,0	11,0	38	100	9	V600, V1300
6	KRF16-12	22	6,0	12,0	13,0	47	100	9	V600, V1300
4	KRF25-6	16,0	8,0	8,0	10,0	39	100	11	V600, V1300
4	KRF25-8	16,0	8,0	8,0	10,0	39	100	11	V600, V1300
4	KRF25-10	17,0	8,0	10,0	11,0	42	100	11	V600, V1300
4	KRF25-12	22	8,0	12,0	13,0	47	100	11	V600, V1300
2	KRF35-6	18,0	9,0	10,0	11,0	47	100	13	V600, V1300
2	KRF35-8	18,0	9,0	10,0	11,0	47	100	13	V600, V1300
2	KRF35-10	18,0	9,0	10,0	11,0	47	100	13	V600, V1300
2	KRF35-12	22	9,0	12,0	14,0	52	100	13	V600, V1300
1/0	KRF50-6	21	11,0	11,0	12,0	50	100	14,5	V600, V1300
1/0	KRF50-8	21	11,0	11,0	12,0	50	100	14,5	V600, V1300
1/0	KRF50-10	21	11,0	11,0	12,0	50	100	14,5	V600, V1300
1/0	KRF50-12	21	11,0	12,0	14,0	53	100	14,5	V600, V1300
1/0	KRF50-16	27	11,0	15,0	17,0	59	100	14,5	V600, V1300
2/0	KRF70-6	25	13,0	11,0	12,0	55	50	17	V600, V1300
2/0	KRF70-8	25	13,0	11,0	12,0	55	50	17	V600, V1300
2/0	KRF70-10	25	13,0	11,0	12,0	55	50	17	V600, V1300
2/0	KRF70-12	25	13,0	12,0	14,0	58	50	17	V600, V1300
2/0	KRF70-16	28	13,0	15,0	17,0	64	50	17	V600, V1300
4/0	KRF95-8	29	15,0	15,0	17,0	69	50	20	V600, V1300
4/0	KRF95-10	29	15,0	15,0	17,0	69	50	20	V600, V1300
4/0	KRF95-12	29	15,0	15,0	17,0	69	50	20	V600, V1300
4/0	KRF95-16	29	15,0	15,0	17,0	69	50	20	V600, V1300
250	KRF120-10	32	17,0	15,0	17,0	73	25	22	V1300, V250
250	KRF120-12	32	17,0	15,0	17,0	73	25	22	V1300, V250
250	KRF120-16	32	17,0	15,0	17,0	73	25	22	V1300, V250
300	KRF150-10	36	19,0	15,0	16,0	80	25	25	V1300, V250
300	KRF150-12	36	19,0	15,0	16,0	80	25	25	V1300, V250
300	KRF150-16	36	19,0	15,0	16,0	80	25	25	V1300, V250
300	KRF150-20	36	19,0	19,0	19,0	87	25	25	V1300, V250
350	KRF185-10	39	21	15,0	16,0	86	20	27	V1300, V250
350	KRF185-12	39	21	15,0	16,0	86	20	27	V1300, V250
350	KRF185-16	39	21	15,0	16,0	86	20	27	V1300, V250
350	KRF185-20	39	21	19,0	19	93	20	27	V1300, V250
500	KRF240A-10	42	22,5	19	20	96	10	30	V1300, V250
500	KRF240A-12	42	22,5	19	20	96	10	30	V1300, V250
500	KRF240A-16	42	22,5	19	20	96	10	30	V1300, V250
500	KRF240A-20	42	22,5	19	20	96	10	30	V1300, V250

** total palm length

Table continue on next page. →

For detailed information regarding recommended tool or system, see chapter 6.

Cu terminals and connectors 0.75 - 1000 mm²

AWG	Cat. no. mm ² - bolt hole M	mm W	d	N	N ₁	L	Pcs/ pack	Die no.	Rec. tool
600	KRF300A-10	46	24,5	15	19	93	10	32	V1300, V250
600	KRF300A-12	46	24,5	15	19	93	10	32	V1300, V250
600	KRF300A-16	46	24,5	20	20	99	10	32	V1300, V250
600	KRF300A-20	46	24,5	23	25	99	10	32	V1300, V250
600	KRF300A-24	46	24,5	23	25	107	10	32	V1300, V250
750	KRF400A-00	56	30	-	-	118	10	38	V1300, V250
750	KRF400A-12	56	30	15	25	111	10	38	V1300, V250
750	KRF400A-16	56	30	20	20	111	10	38	V1300, V250
750	KRF400A-20	56	30	23	25	118	10	38	V1300, V250
750	KRF400A-24	56	30	23	25	118	10	38	V1300, V250
For flexible Cu-conductors									
1000	KRF500-00	61	33	70**		160	5	42	V250
1000	KRF500-16	61	33	25	35	150	5	42	V250
1000	KRF500-20	61	33	25	35	150	5	42	V250
1000	KRF500-24	61	33	25	35	150	5	42	V250
	KRF630-00	75	39	80**		195	1	53	V250
	KRF630-20	75	39	35	45	195	1	53	V250
	KRF630-24	75	39	35	45	195	1	53	V250
	KRF800-00	75	42	80**		195	1	53	V250
	KRF800-24	75	42	35	45	195	1	53	V250
For stranded Cu-conductors									
	KRD500-00	58	31	70**		160	5	40	V250
	KRD500-16	58	31	25	35	150	5	40	V250
	KRD500-20	58	31	25	35	150	5	40	V250
	KRD500-24	58	31	25	35	150	5	40	V250
	KRD630-00	65	34	75**		165	1	45	V250
	KRD630-20	65	34	25	35	150	1	45	V250
	KRD630-24	65	34	25	35	150	1	45	V250
	KRD800-00	75	39	80**		195	1	53	V250
	KRD800-24	75	39	35	45	195	1	53	V250
	KRD1000-00	80	43	80**		195	1	56	V1470

** total palm length

For detailed information regarding recommended tool or system, see chapter 6.

Tube terminals 10 - 1000 mm², KRT

- Data: electrolytic copper, tin plated.
- Cable inspection hole, for stranded (class 2) Cu-conductors.
- UL-approved (KRT 10-500 mm²). DNV-approved (KRT 10-400 mm²).

Marking example KRT: 70 10 (Elpress logotype included)

70 = mm²

10 = palm hole for M10



AWG	Cat. no.	mm W	d	N	N ₁	L	Pcs/ pack	Die no.	Rec. tool
8	KRT10-5	10	4,5	6	8	29	100	7	V600, V1300
8	KRT10-6	10	4,5	6	8	29	100	7	V600, V1300
8	KRT10-8	13	4,5	8	11	34	100	7	V600, V1300
8	KRT10-10	16	4,5	8	11	34	100	7	V600, V1300
8	KRT10-12	19	4,5	10	14	41	100	7	V600, V1300
6	KRT16-5	12	5,5	6	8	34	100	8,5	V600, V1300
6	KRT16-6	12	5,5	6	8	34	100	8,5	V600, V1300
6	KRT16-8	15	5,5	8	11	39	100	8,5	V600, V1300
6	KRT16-10	16	5,5	8	11	39	100	8,5	V600, V1300
6	KRT16-12	19	5,5	10	15	47	100	8,5	V600, V1300
4	KRT25-6	14	7	9	12	43	100	10	V600, V1300
4	KRT25-8	15	7	9	12	43	100	10	V600, V1300
4	KRT25-10	16	7	9	12	43	100	10	V600, V1300
4	KRT25-12	19	7	12	13	48	100	10	V600, V1300
2	KRT35-6	17	8,5	9,5	11,5	49	100	12	V600, V1300
2	KRT35-8	17	8,5	9,5	11,5	49	100	12	V600, V1300
2	KRT35-10	19	8,5	9,5	11,5	49	100	12	V600, V1300
2	KRT35-12	22	8,5	12	14	53	100	12	V600, V1300
1/0	KRT50-6	20	10	11	12	53	100	14	V600, V1300
1/0	KRT50-8	20	10	11	12	53	100	14	V600, V1300
1/0	KRT50-10	20	10	11	12	53	100	14	V600, V1300
1/0	KRT50-12	22	10	12	14	56	100	14	V600, V1300
2/0	KRT70-8	23	12	11	12	55	100	16	V600, V1300
2/0	KRT70-10	23	12	11	12	55	100	16	V600, V1300
2/0	KRT70-12	23	12	12	14	58	100	16	V600, V1300
4/0	KRT95-8	26	13,5	11	12	60	100	18	V600, V1300
4/0	KRT95-10	26	13,5	11	12	60	100	18	V600, V1300
4/0	KRT95-12	26	13,5	12	14	63	100	18	V600, V1300
4/0	KRT95-16	28	13,5	15	17	69	100	18	V600, V1300
250	KRT120-10	28	15	11	14	64	100	19	V1300, V250
250	KRT120-12	28	15	12	14	64	100	19	V1300, V250
250	KRT120-16	28	15	15	17	70	100	19	V1300, V250
300	KRT150-12	32	17	15	17	76	50	22	V1300, V250
300	KRT150-16	32	17	15	17	76	50	22	V1300, V250
300	KRT150-20	32	17	19	20	83	50	22	V1300, V250
350	KRT185-12	35	19	15	17	79	50	24	V1300, V250
350	KRT185-16	35	19	15	17	79	50	24	V1300, V250
350	KRT185-20	35	19	19	20	86	50	24	V1300, V250
500	KRT240-12	38	21	15	17	86	50	26	V1300, V250
500	KRT240-16	38	21	15	17	86	50	26	V1300, V250
500	KRT240-20	38	21	19	20	93	50	26	V1300, V250
600	KRT300-12	44	24	19	20	100	25	30	V1300, V250
600	KRT300-16	44	24	19	20	100	25	30	V1300, V250
600	KRT300-20	44	24	19	20	100	25	30	V1300, V250

** total palm length

Table continue on next page. →

For detailed information regarding recommended tool or system, see chapter 6.

Cu terminals and connectors 0.75 - 1000 mm²

AWG	Cat. no.	mm W	d	N	N ₁	L	Pcs/ pack	Die no.	Rec. tool
750	KRT400-16	48	26	21	31	114	25	32	V1300, V250
750	KRT400-20	48	26	21	31	114	25	32	V1300, V250
750	KRT400-24	48	26	21	31	114	25	32	V1300, V250
1000	KRT500-00	58	31	70**	-	160	-	40	V250
1000	KRT500-16	58	31	25	35	150	-	40	V250
1000	KRT500-20	58	31	25	35	150	-	40	V250
1000	KRT500-24	58	31	25	35	150	-	40	V250
	KRT630-00	65	34	70**	-	160	-	45	V250
	KRT630-20	65	34	25	35	150	-	45	V250
	KRT630-24	65	34	25	35	150	-	45	V250
	KRT800-00	75	39	80**	-	195	-	53	V250
	KRT800-24	75	39	35	45	195	-	53	V250
	KRT1000-00	80	43	80**	-	195	-	56	V1470

** total palm length

For detailed information regarding recommended tool or system, see chapter 6.

Tube terminals 16 - 1000 mm², KR D

■ Data: electrolytic copper, tin plated.

■ Cable inspection hole, for stranded (class 2) Cu-conductors.

Marking example KR D: 70 10 (Elpress logotype included)

70 = mm²

10 = palm hole for M10

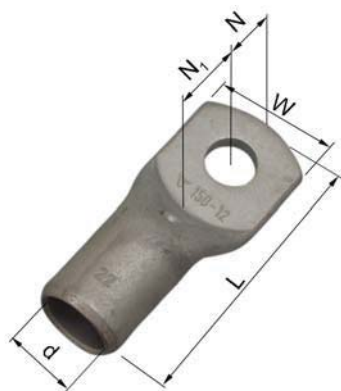

Cat. no.	mm W	d	N	N ₁	L	Pcs/ pack	Die no.	Rec. tool
KRD16-5	12	5,4	6	8	29	100	8	V600, V1300
KRD16-6	12	5,4	6	8	29	100	8	V600, V1300
KRD16-8	14	5,4	8	9	33	100	8	V600, V1300
KRD16-10	16	5,4	8	10	34	100	8	V600, V1300
KRD16-12	18	5,4	10	14	41	100	8	V600, V1300
KRD25-6	13	6,7	7	9	32	100	9	V600, V1300
KRD25-8	13	6,7	7	9	32	100	9	V600, V1300
KRD25-10	16	6,7	10	12	38	100	9	V600, V1300
KRD25-12	22	6,7	12	13	47	100	9	V600, V1300
KRD35-6	16	8	8	10	39	100	11	V600, V1300
KRD35-8	16	8	8	10	39	100	11	V600, V1300
KRD35-10	17	8	10	11	42	100	11	V600, V1300
KRD35-12	22	8	12	13	47	100	11	V600, V1300
KRD50-6	18	9,5	8,5	11,5	44	100	12	V600, V1300
KRD50-8	18	9,5	8,5	11,5	44	100	12	V600, V1300
KRD50-10	18	9,5	9,5	11,5	49	100	12	V600, V1300
KRD50-12	20	9,5	12	14	53	100	12	V600, V1300
KRD70-8	22	11,3	11	12	54	50	14	V600, V1300
KRD70-10	22	11,3	11	12	54	50	14	V600, V1300
KRD70-12	22	11,3	12	14	57	50	14	V600, V1300
KRD95-8	24	13	11	12	58	50	16	V600, V1300
KRD95-10	24	13	11	12	58	50	16	V600, V1300
KRD95-12	24	13	12	14	61	50	16	V600, V1300
KRD95-16	28	13	15	17	67	50	16	V600, V1300
KRD120-10	28	15	11	15	64	50	19	V1300, V250
KRD120-12	28	15	11	15	64	50	19	V1300, V250
KRD120-16	28	15	15	17	70	50	19	V1300, V250
KRD150-12	32	17	15	17	76	50	22	V1300, V250
KRD150-16	32	17	15	17	76	50	22	V1300, V250
KRD150-20	32	17	19	20	83	50	22	V1300, V250
KRD185-12	36	19	15	17	80	50	25	V1300, V250
KRD185-16	36	19	15	17	80	50	25	V1300, V250
KRD185-20	36	19	19	20	87	50	25	V1300, V250
KRD240-12	39	21	15	17	86	50	27	V1300, V250
KRD240-16	39	21	15	17	86	50	27	V1300, V250
KRD240-20	39	21	19	20	93	50	27	V1300, V250
KRD300-12	44	24	19	20	100	25	30	V1300, V250
KRD300-16	44	24	19	20	100	25	30	V1300, V250
KRD300-20	44	24	19	20	100	25	30	V1300, V250
KRD400-16	48	26	22	31	116	25	32	V1300, V250
KRD400-20	48	26	22	31	116	25	32	V1300, V250
KRD400-24	48	26	22	31	116	25	32	V1300, V250
KRD500-00	58	31	70**		160	5	40	V250
KRD500-16	58	31	25	35	150	5	40	V250
KRD500-20	58	31	25	35	150	5	40	V250
KRD500-24	58	31	25	35	150	5	40	V250

** total palm length

Table continue on next page. →

For detailed information regarding recommended tool or system, see chapter 6.

Cu terminals and connectors 0.75 - 1000 mm²

Cat. no.	mm W	d	N	N ₁	L	Pcs/pack	Die no.	Rec. tool
KRD630-00	65	34	75**		165	1	45	V250
KRD630-20	65	34	25	35	150	1	45	V250
KRD630-24	65	34	25	35	150	1	45	V250
KRD800-00	75	39	80**		195	1	53	V250
KRD800-24	75	39	35	45	195	1	53	V250
KRD1000-00	80	43	80**		195	1	56	V1470

** total palm length

Cu terminals 50 - 240 mm², KRFN, with narrow palm

- Data: electrolytic copper, tin plated.
- Cable inspection hole, for stranded (class 2) and flexible (class 5) Cu-conductors.
- Easy to mount through conduits, enables pre-assembly.

Marking example KRF: 70 10F (Elpress logotype included)

70 = mm² 10 = palm hole for M10 F = type KRF, for stranded and flexible conductors

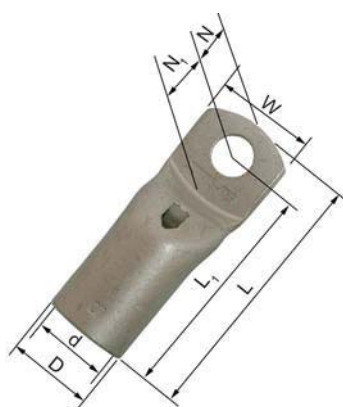

KRFN terminals suitable for narrow spaces.



Easy to mount through conduits.

Cat. no. mm ² , Bolt	mm W	d	D	N	N ₁	L ₁	L	Pcs/Pack	Die no.	Rec. tool
KRFN50-6	18	11	14,5	11	11	40	51	100	14,5	V600, V1300
KRFN50-8	18	11	14,5	11	11,5	40	51	100	14,5	V600, V1300
KRFN50-10	18	11	14,5	11	11,5	40	51	100	14,5	V600, V1300
KRFN70-6	20	13,0	17,0	11	11,5	45	56	50	14,5	V600, V1300
KRFN70-8	20	13,0	17,0	11	11,5	45	56	50	17	V600, V1300
KRFN70-10	20	13,0	17,0	11	11,5	45	56	50	17	V600, V1300
KRFN95-8	24	15,0	20,0	11	12	50	61	50	20	V600, V1300
KRFN95-10	24	15,0	20,0	11	13	51	62	50	20	V600, V1300
KRFN95-12	24	15,0	20,0	12	14	52	64	50	20	V600, V1300
KRFN120-8	26	17,0	22,0	11	12	54	65	50	22	V1300, V250
KRFN120-10	26	17,0	22,0	11	13	55	66	50	22	V1300, V250
KRFN120-12	26	17,0	22,0	12	14	56	68	50	22	V1300, V250
KRFN150-10	30	19,0	25,0	11	13	62	73	50	25	V1300, V250
KRFN150-12	30	19,0	25,0	12	14	63	75	50	25	V1300, V250
KRFN185-10	32	21,0	27,0	11	14	69	80	25	27	V1300, V250
KRFN185-12	32	21,0	27,0	12	15	70	82	25	27	V1300, V250
KRFN185-16	32	21,0	27,0	15	16	71	86	25	27	V1300, V250
KRFN240A-10	38	22,5	29,0	11	16	73	84	50	30	V1300, V250
KRFN240A-12	38	22,5	29,0	12	15	72	84	50	30	V1300, V250
KRFN240A-16	38	22,5	29,0	15	18	75	90	50	30	V1300, V250

For detailed information regarding recommended tool or system, see chapter 6.

Tube terminals with two stud holes 35 - 400 mm², KRF

- Data: electrolytic copper, tin plated.
- Cable inspection hole, for stranded (class 2) and flexible (class 5) Cu-conductors.
- UL-approved (KRF 35-400 mm²). DNV-approved (marked with *).

Marking example KRF: 70 10F (Elpress logotype included)

70 = mm² 10 = palm hole for M10 F = type KRF, for flexible and stranded conductors

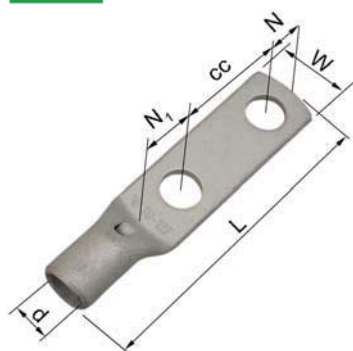

AWG	Cat. no. mm ² , bolt hole, cc-measure	mm W	d	N	N ₁	L	Pcs/ pack	Die no.	Rec. tool
2	KRF35-10X2-24-26	18,5	9	11	16	78	100	13	V600, V1300
1/0	KRF50-10X2-24-26	20,5	11	11	16	82	100	14,5	V600, V1300
2/0	KRF70-10x2-24-26	25	13,0	11	17	86	50	17	V600, V1300
2/0	KRF70-12X2-40*	25	13,0	12	18	103	25	17	V600, V1300
4/0	KRF95-10X2-24-26	29	15,0	11	19	93	25	20	V600, V1300
4/0	KRF95-12X2-40*	29	15,0	12	18	109	25	20	V600, V1300
250	KRF120-10X2-24-26	32	17,0	11	19	97	25	22	V1300, V250
250	KRF120-12X2-40*	32	17,0	12	19	113	25	22	V1300, V250
300	KRF150-10X2-24-26	36	19,0	11	19	104	25	25	V1300, V250
300	KRF150-12X2-40	36	19,0	12	19	120	20	25	V1300, V250
350	KRF185-10X2-24-26	39	21	13	19	111	20	27	V1300, V250
350	KRF185-12X2-40*	39	21	12	20	126	20	27	V1300, V250
500	KRF240A-10X2-24-26	42	22,5	11	22	115	10	30	V1300, V250
500	KRF240A-12X2-40*	42	22,5	12	21	130	10	30	V1300, V250
600	KRF300A-12X2-40*	46	24,5	12	22	133	5	32	V1300, V250
750	KRF400A-12X2-40	56	30	12	23	145	1	38	V1300, V250

* DNV-approved



For detailed information regarding recommended tool or system, see chapter 6.

Tube terminals 45°, 10 - 150 mm², KRF

- Data: electrolytic copper, tin plated.
- Cable inspection hole, for stranded (class 2) and flexible (class 5) Cu-conductors.
- UL-approved (KRF 35-150 mm²). DNV-approved (16-150 mm²).

Marking example KRF: 70 10F (Elpress logotype included)

70 = mm² 10 = palm hole for M10 F = type KRF, for stranded and flexible conductors

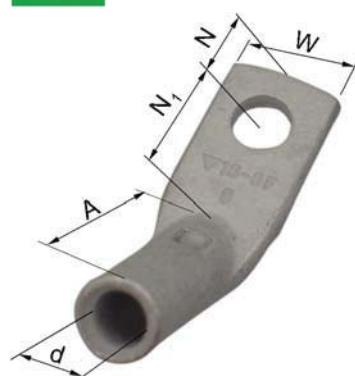

AWG	Cat. no. mm ² , Bolt, 45°	mm W	d	N	N ₁	A	Pcs/ pack	Die no.	Rec. tool
8	KR10-6-45GR	13,0	5,0	6,5	11,5	19	100	8	V600, V1300
8	KR10-8-45GR	13,5	5,0	8,5	12,0	19	100	8	V600, V1300
6	KRF16-6-45GR	13,0	6,0	6,5	11,5	23	100	9	V600, V1300
6	KRF16-8-45GR	13,5	6,0	8,5	12,0	23	100	9	V600, V1300
4	KRF25-6-45GR	17,0	8,0	6,5	11,5	24	100	11	V600, V1300
4	KRF25-8-45GR	17,0	8,0	8,5	12,0	24	100	11	V600, V1300
4	KRF25-10-45GR	17,0	8,0	11,5	13,5	24	100	11	V600, V1300
2	KRF35-6-45GR	18,0	9,0	6,5	11,5	30	100	13	V600, V1300
2	KRF35-8-45GR	18,0	9,0	8,5	12,0	30	100	13	V600, V1300
2	KRF35-10-45GR	18,0	9,0	11,5	13,5	30	100	13	V600, V1300
1/0	KRF50-8-45GR	21	11,0	8,5	17,5	31	100	14,5	V600, V1300
1/0	KRF50-10-45GR	21	11,0	11,5	18,5	31	100	14,5	V600, V1300
1/0	KRF50-12-45GR	21	11,0	12,5	19,5	31	100	14,5	V600, V1300
2/0	KRF70-8-45GR	25	13,0	8,5	17,5	35	50	17	V600, V1300
2/0	KRF70-10-45GR	25	13,0	11,5	18,5	35	50	17	V600, V1300
2/0	KRF70-12-45GR	25	13,0	12,5	19,5	35	50	17	V600, V1300
4/0	KRF95-10-45GR	29	15,0	11,5	18,5	40	50	20	V600, V1300
4/0	KRF95-12-45GR	29	15,0	12,5	19,5	40	50	20	V600, V1300
4/0	KRF95-16-45GR	29	15,0	15,5	20,5	40	50	20	V600, V1300
250	KRF120-10-45GR	32	17,0	11,5	18,5	43	25	22	V1300, V250
250	KRF120-12-45GR	32	17,0	12,5	19,5	43	25	22	V1300, V250
250	KRF120-16-45GR	32	17,0	15,5	20,4	43	25	22	V1300, V250
300	KRF150-10-45GR	36	19,0	11,5	18,5	49	25	25	V1300, V250
300	KRF150-12-45GR	36	19,0	12,5	19,5	49	25	25	V1300, V250
300	KRF150-16-45GR	36	19,0	15,5	20,5	49	25	25	V1300, V250

For detailed information regarding recommended tool or system, see chapter 6.

Tube terminals 45°, 10 - 120 mm², KRT

- Data: electrolytic copper, tin plated.
- Without cable inspection hole, for stranded (class 2) Cu-conductors.
- UL-approved. DNV-approved.

Marking example KRF: 70 10F (Elpress logotype included)

70 = mm² 10 = palm hole for M10 F = type KRF, for stranded and flexible conductors

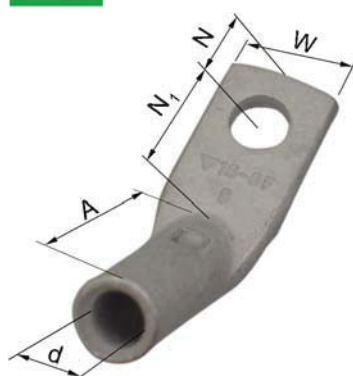

AWG	Cat. no.	mm W	d	N	N ₁	A	Pcs/pack	Die no.	Rec. tool
8	KRT10-6NS-45GR	13	4,5	6,5	11,5	20	100	7	V600, V1300
8	KRT10-8NS-45GR	13,5	4,5	8,5	12	20	100	7	V600, V1300
6	KRT16-6NS-45GR	13	5,4	6,5	11,5	23	100	8,5	V600, V1300
6	KRT16-8NS-45GR	13,5	5,4	8,5	12	23	100	8,5	V600, V1300
6	KRT16-10NS-45GR	16	5,4	11,5	13,5	23	100	8,5	V600, V1300
4	KRT25-6NS-45GR	14	7	6,5	11,5	26	100	10	V600, V1300
4	KRT25-8NS-45GR	14	7	8,5	12	26	100	10	V600, V1300
4	KRT25-10NS-45GR	16	7	11,5	13,5	26	100	10	V600, V1300
2	KRT35-6NS-45GR	17	8,5	6,5	11,5	30	100	12	V600, V1300
2	KRT35-8NS-45GR	17	8,5	8,5	12	30	100	12	V600, V1300
2	KRT35-10NS-45GR	19	8,5	11,5	13,5	30	100	12	V600, V1300
1/0	KRT50-8NS-45GR	20	10	8,5	17,5	32	100	14	V600, V1300
1/0	KRT50-10NS-45GR	20	10	11,5	18,5	32	100	14	V600, V1300
1/0	KRT50-12NS-45GR	22	10	12,5	19,5	32	100	14	V600, V1300
2/0	KRT70-8NS-45GR	23	12	8,5	17,5	38	50	16	V600, V1300
2/0	KRT70-10NS-45GR	23	12	11,5	18,5	38	50	16	V600, V1300
2/0	KRT70-12NS-45GR	23	12	12,5	19,5	38	50	16	V600, V1300
4/0	KRT95-8NS-45GR	28	13,5	8,5	17,5	38	50	18	V600, V1300
4/0	KRT95-10NS-45GR	28	13,5	11,5	18,5	38	50	18	V600, V1300
4/0	KRT95-12NS-45GR	28	13,5	12,5	19,5	38	50	18	V600, V1300
4/0	KRT95-16NS-45GR	28	13,5	15,5	20,5	38	50	18	V600, V1300
250	KRT120-10NS-45GR	29	15	11,5	18,5	41	25	19	V600, V1300
250	KRT120-12NS-45GR	29	15	12,5	19,5	41	25	19	V600, V1300
250	KRT120-16NS-45GR	29	15	15,5	20,5	41	25	19	V600, V1300



For detailed information regarding recommended tool or system, see chapter 6.

Tube terminals 90° degrees 10 - 150 mm², KRF

- Data: electrolytic copper, tin plated.
- Cable inspection hole, for stranded (class 2) and flexible (class 5) Cu-conductors.
- UL-approved (35-150 mm²). DNV-approved (16-150 mm²).

Marking example KRF: 70 10F (Elpress logotype included)

70 = mm² 10 = palm hole for M10 F = type KRF, for stranded and flexible conductors



AWG	Cat. no. mm ² , Bolt	mm W	d	N	N ₁	A	Pcs/ pack	Die no.	Rec. tool
8	KR10-6-90GR	13,0	5,0	6,5	11,5	15	100	8	V600, V1300
8	KR10-8-90GR	13,5	5,0	8,5	12,0	15	100	8	V600, V1300
6	KRF16-6-90GR	13,0	6,0	6,5	11,5	16,5	100	9	V600, V1300
6	KRF16-8-90GR	13,5	6,0	8,5	12,0	16,5	100	9	V600, V1300
4	KRF25-6-90GR	17,0	8,0	6,5	11,5	18,5	100	11	V600, V1300
4	KRF25-8-90GR	17,0	8,0	8,5	12,0	18,5	100	11	V600, V1300
4	KRF25-10-90GR	17,0	8,0	11,5	13,5	18,5	100	11	V600, V1300
2	KRF35-6-90GR	18,0	9,0	6,5	11,5	22,5	100	13	V600, V1300
2	KRF35-8-90GR	18,0	9,0	8,5	12,0	22,5	100	13	V600, V1300
2	KRF35-10-90GR	18,0	9,0	11,5	13,5	22,5	100	13	V600, V1300
1/0	KRF50-8-90GR	21	11,0	8,5	17,5	30,5	100	14,5	V600, V1300
1/0	KRF50-10-90GR	21	11,0	11,5	18,5	30,5	100	14,5	V600, V1300
1/0	KRF50-12-90GR	21	11,0	12,5	19,5	30,5	100	14,5	V600, V1300
2/0	KRF70-8-90GR	25	13,0	8,5	17,5	31,5	50	17	V600, V1300
2/0	KRF70-10-90GR	25	13,0	11,5	18,5	31,5	50	17	V600, V1300
2/0	KRF70-12-90GR	25	13,0	12,5	19,5	31,5	50	17	V600, V1300
4/0	KRF95-10-90GR	29	15,0	11,5	18,5	32,5	50	20	V600, V1300
4/0	KRF95-12-90GR	29	15,0	12,5	19,5	32,5	50	20	V600, V1300
4/0	KRF95-16-90GR	29	15,0	15,5	20,5	32,5	50	20	V600, V1300
250	KRF120-10-90GR	32	17,0	11,5	18,5	34,5	25	22	V1300, V250
250	KRF120-12-90GR	32	17,0	12,5	19,5	34,5	25	22	V1300, V250
250	KRF120-16-90GR	32	17,0	15,5	20,5	34,5	25	22	V1300, V250
300	KRF150-10-90GR	36	19,0	11,5	18,5	37,5	25	25	V1300, V250
300	KRF150-12-90GR	36	19,0	12,5	19,5	37,5	25	25	V1300, V250
300	KRF150-16-90GR	36	19,0	15,5	20,5	37,5	25	25	V1300, V250

For detailed information regarding recommended tool or system, see chapter 6.

Tube terminals 90° degrees 10 - 120 mm², KRT

- Data: electrolytic copper, tin plated.
- For stranded (class 2) Cu-conductors.
- KRT-types are without inspection hole (NS).
- UL-approved. DNV-approved.

Marking example KRF: 70 10F (Elpress logotype included)

70 = mm² 10 = palm hole for M10 F = type KRF, for stranded and flexible conductors



AWG	Cat. no.	mm W	d	N	N ₁	A	Pcs/Pack	Die no.	Rec. tool
8	KRT10-6NS-90GR	13	4,5	6,5	11,5	15,5	100	7	V600, V1300
8	KRT10-8NS-90GR	13,5	4,5	8,5	12	15,5	100	7	V600, V1300
6	KRT16-6NS-90GR	13	5,4	6,5	11,5	16,5	100	8,5	V600, V1300
6	KRT16-8NS-90GR	13,5	5,4	8,5	12	16,5	100	8,5	V600, V1300
6	KRT16-10NS-90GR	16	5,4	11,5	13,5	17	100	8,5	V600, V1300
4	KRT25-6NS-90GR	14	7	6,5	11,5	20	100	10	V600, V1300
4	KRT25-8NS-90GR	14	7	8,5	12	20	100	10	V600, V1300
4	KRT25-10NS-90GR	16	7	11,5	13,5	20	100	10	V600, V1300
2	KRT35-6NS-90GR	17	8,5	6,5	11,5	23,5	100	12	V600, V1300
2	KRT35-8NS-90GR	17	8,5	8,5	12	23,5	100	12	V600, V1300
2	KRT35-10NS-90GR	19	8,5	11,5	13,5	23,5	100	12	V600, V1300
1/0	KRT50-6NS-90GR	22	10	8,5	12	32,5	100	14	V600, V1300
1/0	KRT50-8NS-90GR	20	10	11,5	17,5	31,5	100	14	V600, V1300
1/0	KRT50-10NS-90GR	20	10	12,5	18,5	31,5	100	14	V600, V1300
2/0	KRT70-8NS-90GR	23	12	8,5	17,5	32,5	50	16	V600, V1300
2/0	KRT70-10NS-90GR	23	12	11,5	18,5	32,5	50	16	V600, V1300
2/0	KRT70-12NS-90GR	23	12	12,5	19,5	32,5	50	16	V600, V1300
4/0	KRT95-8NS-90GR	28	13,5	8,5	17,5	32,5	50	18	V600, V1300
4	KRT95-10NS-90GR	28	13,5	11,5	18,5	32,5	50	18	V600, V1300
4	KRT95-12NS-90GR	28	13,5	12,5	19,5	32,5	50	18	V600, V1300
4	KRT95-16NS-90GR	28	13,5	15,5	20,5	32,5	50	18	V600, V1300
250	KRT120-10NS-90GR	28	15	11,5	18,5	34,5	25	19	V600, V1300
250	KRT120-12NS-90GR	28	15	12,5	19,5	34,5	25	19	V600, V1300
250	KRT120-16NS-90GR	28	15	15,5	20,5	34,5	25	19	V600, V1300

For detailed information regarding recommended tool or system, see chapter 6.

Tube terminals 10 - 300 mm² DIN 46235

■ Data: electrolytic copper, tin plated.

■ Dimensions according to DIN 46235, number of crimps marked on the neck of the terminal.

Palm marking example: 70 10

70 = mm²

10 = palm hole for M10



Cat. no. mm ² , bolt	mm W	d	L	Pcs/ pack	DIN die no.	Rec tool
KR10-6DIN	9,0	4,4	27	100	6	V600, V1300
KR16-6DIN	13,0	5,5	36	100	8	V600, V1300
KR16-8DIN	13,0	5,5	37	100	8	V600, V1300
KR16-10DIN	16,5	5,5	38	100	8	V600, V1300
KR25-6DIN	14,0	7,0	39	100	10	V600, V1300
KR25-8DIN	17,0	7,0	39	100	10	V600, V1300
KR25-10DIN	17,0	7,0	40,5	100	10	V600, V1300
KR25-12DIN	18,0	7,0	40,5	100	10	V600, V1300
KR35-8DIN	18,0	8,2	42	100	12	V600, V1300
KR35-10DIN	19,0	8,2	42	100	12	V600, V1300
KR35-12DIN	21	8,2	43	100	12	V600, V1300
KR50-8DIN	20	10,0	52	100	14	V600, V1300
KR50-10DIN	22	10,0	52	100	14	V600, V1300
KR50-12DIN	24	10,0	52	100	14	V600, V1300
KR50-16DIN	28	10,0	55,5	100	14	V600, V1300
KR70-10DIN	24	11,3	56	50	16	V600, V1300
KR70-12DIN	24	11,3	56,5	50	16	V600, V1300
KR70-16DIN	29	11,3	57	50	16	V600, V1300
KR95-10DIN	28	13,5	65,5	50	18	V600, V1300
KR95-12DIN	28	13,5	65,5	50	18	V600, V1300
KR95-16DIN	32	13,5	65,5	50	18	V600, V1300
KR120-12DIN	31	15,5	70,5	50	20	V1300, V250
KR120-16DIN	31,5	15,5	72	25	20	V1300, V250
KR120-20DIN	36	15,5	72	25	20	V1300, V250
KR150-12DIN	34	17,0	78,5	25	22	V1300, V250
KR150-16DIN	34	17,0	78	25	22	V1300, V250
KR150-20DIN	38	17,0	78	25	22	V1300, V250
KR185-12DIN	37	19,0	82,5	25	25	V1300, V250
KR185-16DIN	37	19,0	82	25	25	V1300, V250
KR185-20DIN	40	19,0	83	25	25	V1300, V250
KR240-12DIN	42,5	21,5	92	10	28	V1300, V250
KR240-16DIN	42,5	22	92	10	28	V1300, V250
KR240-20DIN	45	22	92	25	28	V1300, V250
KR300-16DIN	48,5	24,5	100	10	32	V1300, V250
KR300-20DIN	48,5	24	100	10	32	V1300, V250

For detailed information regarding recommended tool or system, see chapter 6.

Sheet metal terminals 10 - 240 mm² DIN 46234

- Data: electrolytic copper, tin plated.
- Dimensions according to DIN 46234.

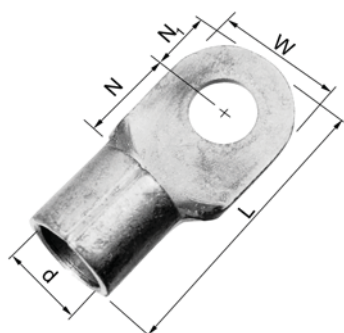

Cat. no. mm ² , bolt	mm W	d	N1	N	L	Pcs/ pack	Palm marking	Die no.	Rec. tool
B10-5R	10,0	4,5	5,0	8,0	21	100	10	7	GWB4010, V600
B10-6R	11,0	4,5	5,5	9,0	23	100	10	7	GWB4010, V600
B10-8R	14,0	4,5	7,0	12,0	27	100	10	7	GWB4010, V600
B10-10R	18,0	4,5	9,0	13,0	30	100	10	7	GWB4010, V600
B10-12R	22	4,5	11,0	15,0	34	100	10	7	GWB4010, V600
B16-5R	11,0	5,8	5,5	10,0	26	100	16	8	V600, V1300
B16-6R	11,0	5,8	5,5	10,0	26	100	16	8	V600, V1300
B16-8R	14,0	5,8	7,0	12,0	29	100	16	8	V600, V1300
B16-10R	18,0	5,8	9,0	14,0	33	100	16	8	V600, V1300
B16-12R	22	5,8	11,0	16,0	37	100	16	8	V600, V1300
B25-5R	12,0	7,5	6,0	14,0	31	100	25	10	V600, V1300
B25-6R	12,0	7,5	6,0	14,0	31	100	25	10	V600, V1300
B25-8R	16,0	7,5	8,0	14,0	33	100	25	10	V600, V1300
B25-10R	18,0	7,5	9,0	15,0	35	100	25	10	V600, V1300
B25-12R	22	7,5	11,0	20	42	100	25	10	V600, V1300
B25-16R	28	7,5	14,0	24	49	100	25	10	V600, V1300
B35-6R	15,0	9,0	7,5	14,0	34	100	35	12	V600, V1300
B35-8R	16,0	9,0	8,0	14,0	34	100	35	12	V600, V1300
B35-10R	18,0	9,0	9,0	15,0	36	100	35	12	V600, V1300
B35-12R	22	9,0	11,0	19,0	42	100	35	12	V600, V1300
B35-16R	28	9,0	14,0	24	50	100	35	12	V600, V1300
B50-6R	18,0	11,0	9,0	18,0	43	100	50	14,5	V600, V1300
B50-8R	18,0	11,0	9,0	18,0	43	100	50	14,5	V600, V1300
B50-10R	18,0	11,0	9,0	18,0	43	100	50	14,5	V600, V1300
B50-12R	22	11,0	11,0	20	47	100	50	14,5	V600, V1300
B50-16R	28	11,0	14,0	24	54	100	50	14,5	V600, V1300
B70-8R	22	13,0	11,0	20	49	100	70	17	V600, V1300
B70-10R	22	13,0	11,0	20	49	100	70	17	V600, V1300
B70-12R	22	13,0	11,0	20	49	100	70	17	V600, V1300
B70-16R	28	13,0	14,0	24	56	100	70	17	V600, V1300
B95-10R	24	15,0	12,0	22	54	100	95	20	V600, V1300
B95-12R	24	15,0	12,0	22	54	100	95	20	V600, V1300
B95-16R	28	15,0	14,0	24	58	100	95	20	V600, V1300
B120-10R	24	16,5	12,0	22	56	50	120	Contact elpress	V600, V1300
B120-12R	24	16,5	12,0	22	56	50	120	Contact elpress	V600, V1300
B120-16R	28	16,5	14,0	26	62	50	120	Contact elpress	V600, V1300
B150-12R	30	19,0	15,0	26	65	50	150	Contact elpress	V600, V1300
B150-16R	30	19,0	15,0	26	65	50	150	Contact elpress	V600, V1300
B185-12R	36	21	18,0	22	68	50	185	Contact elpress	V1300, V250
B185-16R	36	21	18,0	22	68	50	185	Contact elpress	V1300, V250
B240-12R	38	24	19,0	24	75	50	240	Contact elpress	V1300, V250
B240-16R	38	24	19,0	24	75	50	240	Contact elpress	V1300, V250



For detailed information regarding recommended tool or system, see chapter 6.

Through connectors 0,75 - 800 mm², KS/KSF

- Data: electrolytic copper, tin plated.
- Cable inspection hole and cable stop, for stranded (class 2) and flexible (class 5) Cu-conductors.
- UL-approved (1-500 mm²). DNV-approved (16-400 mm²).

Marking example: 20 95F 111 (earth-sign) Elpress logotype included

20 = die no. 95 = mm² F = type KSF, stranded and flexible conductors

111 = screen, mm²



AWG	Cat. no. mm ²	Screen cross section	mm d	D	L	Pcs/ pack	Die no.	Rec. tool
(22)-18	KS0,75		1,3	2,8	14,0	100		DKB0760
(18)-16	KS1,5		1,8	3,3	14,0	100		DKB0760
(16)-14	KS2,5		2,3	4,2	16,0	100		DKB0760
12	KS4		3,0	5,0	19,0	100		GWB4099, ES2258
10	KS6		4,0	6,0	19,0	100		GWB4099, ES2258
8	KS10		5,0	8,0	30	100	8	GWB4099, ES2258
6	KSF16	15	6,0	9,0	35	100	9	V600, V1300
4	KSF25	21-29	8,0	11,0	35	100	11	V600, V1300
2	KSF35	41	9,0	13,0	35	100	13	V600, V1300
1/0	KSF50	57	11,0	14,5	45	50	14,5	V600, V1300
2/0	KSF70	72-88	13,0	17,0	45	50	17	V600, V1300
4/0	KSF95	111	15,0	20	45	50	20	V600, V1300
250	KSF120		17,0	22	55	50	22	V1300, V250
300	KSF150		19,0	25	65	25	25	V1300, V250
350	KSF185		21	27	70	25	27	V1300, V250
500	KSF240A		22,5	29	70	25	30	V1300, V250
600	KSF300A		24	31,5	75	10	32	V1300, V250
750	KSF400A		30	38	100	10	38	V1300, V250
For flexible Cu-conductors								
1000	KSF500		33	42	135	5	42	V250
	KSF630		39	53	175	3	53	V250
	KSF800		42	53	175	2	53	V250

For detailed information regarding recommended tool or system, see chapter 6.

Through connectors 10 - 800 mm², KST

- Data: electrolytic copper, tin plated.
- Cable inspection hole and cable stop, for stranded (class 2) Cu-conductors.
- UL-approved (10-500 mm²). DNV-approved (10-400 mm²).

Marking example: 18 95 Elpress logotype included

18 = die no. 95 = mm²



AWG	Cat. no.	mm d	D	L	Pcs/Pack	Die no.	Rec. tool
8	KST10	4,5	7	30	100	7	GWB4099
6	KST16	5,5	8,5	35	100	8,5	V600, V1300
4	KST25	7	10	40	100	10	V600, V1300
2	KST35	8,5	12	45	100	12	V600, V1300
1/0	KST50	10	14	50	50	14	V600, V1300
2/0	KST70	12	16	55	50	16	V600, V1300
4/0	KST95	13,5	18	60	50	18	V600, V1300
250	KST120	15	19	60	50	19	V1300, V250
300	KST150	17	22	65	50	22	V1300, V250
350	KST185	19	24	75	50	24	V1300, V250
500	KST240	21	26	85	50	26	V1300, V250
600	KST300	24	30	90	50	30	V1300, V250
750	KST400	26	32	90	50	32	V1300, V250
1000	KST500	31	40	135	5	40	V250
	KST630	34	45	135	5	45	V250
	KST800	39	53	175	1	53	V250



Through connectors 16 - 800 mm², KSD

- Data: electrolytic copper, tin plated.
- Cable inspection hole and cable stop, for stranded (class 2) Cu-conductors.

Marking example: 16 95 Elpress logotype included

16 = die no. 95 = mm²



Cat. no.	mm d	D	L	Pcs/Pack	Die no.	Rec. tool
KSD16	5,4	8	35	100	8	V600, V1300
KSD25	6,7	9	30	100	9	V600, V1300
KSD35	8	11	35	100	11	V600, V1300
KSD50	9,5	12	40	50	12	V600, V1300
KSD70	11,3	14	45	50	14	V600, V1300
KSD95	13	16	55	50	16	V600, V1300
KSD120	15	19	60	50	19	V1300, V250
KSD150	17	22	65	50	22	V1300, V250
KSD185	19	25	70	50	25	V1300, V250
KSD240	21	27	70	50	27	V1300, V250
KSD300	24	30	90	50	30	V1300, V250
KSD400	26	32	90	25	32	V1300, V250
KSD500	31	40	135	5	40	V250
KSD630	34	45	135	5	45	V250
KSD800	39	53	175	1	53	V250

For detailed information regarding recommended tool or system, see chapter 6.

Through connectors with partition 10 - 400 mm²

- Data: electrolytic copper, tin plated.
- With partition to prevent oil-leakage, for stranded (class 2) and flexible (class 5) Cu-conductors.

Marking example: 20 95F 111 (earth-sign) Elpress logotype included

20 = die no. 95 = mm² F = type KSF, stranded and flexible conductors

111 = screen, mm²



Cat.no. mm ²	Screen cond. area	mm d	D	L	Pcs/ pack	Die no.	Rec. tool
KS10M		5,0	8,0	36	100	8	GWB4099,V600
KSF16M	15	6,0	9,0	37	100	9	V600, V1300
KSF25M	21-29	8,0	11,0	38	100	11	V600, V1300
KSF35M	41	9,0	13,0	41	100	13	V600, V1300
KSF50M	57	11,0	14,5	48	50	14,5	V600, V1300
KSF70M	72-88	13,0	17,0	49	50	17	V600, V1300
KSF95M	111	15,0	20	56	50	20	V600, V1300
KSF120M		17,0	22	63	50	22	V1300, V250
KSF150M		19,0	25	64	25	25	V1300, V250
KSF185M		21	27	74	25	27	V1300, V250
KSF240AM		22,5	29	76	1	30	V1300, V250
KSF300AM		24,5	31,5	88	1	32	V1300, V250
KSF400AM		30,0	36	105	1	38	V1300, V250

Parallel connectors for total cross section areas 0.5 - 7.5 mm²

- Data: electrolytic copper, tin plated.
- For flexible (class 5) and stranded (class 2) Cu-conductors.



mm ² Total	Cat. no.	mm d	D	L	Pcs/ pack	Marking	Rec. tool
0,5-1,5	KS2x1P	1,6	3,2	7,0	100	-	DKB0325
1,5-3,5	KS2x2,5P	2,3	3,9	7,0	100	-	DKB0325
4-7,5	KS2x6P	3,6	5,6	7,0	100	-	DKB0760

Connectors for solid Cu conductors 6 - 16 mm²

- Data: electrolytic copper.
- For solid conductors (to IEC 60228 class 1).



mm ²	Cat. no.	Corresponding KS-connector	mm d	D	L	Pcs/ pack	Marking*	Rec. tool
6	CUT6	KS4	3,0	5,0	27	100	CUT6	ES2258
10	CUT10	KS6	4,0	6,0	27	100	CUT10	ES2258
16	CUT16	KS10	5,0	8,0	35	100	CUT16	EL2258

* Elpress logotype included in marking.

For detailed information regarding recommended tool or system, see chapter 6.

Pin terminals 10 - 95 mm² DIN 46230

- Data: electrolytic copper, tin plated.
- Dimensions according to DIN 46230.



mm ²	Cat. no.	mm W	L ₁	L	Inner Ø d	Pcs/pack	Die no.	Rec. tool
10	B10SR	4,3	12,0	22	4,5	100	7	V600, V1300
16	B16SR	5,5	13,0	26	5,8	100	8	V600, V1300
25	B25SR	6,8	15,0	34	7,0	100	10	V600, V1300
35	B35SR	8,0	20	41	8,7	100	12	V600, V1300
50	B50SR	9,5	20	45	9,8	50	14,5	V600, V1300
70	B70SR	11,0	23	55	11,5	50	17	V600, V1300
95	B95SR	12,3	23	55	13,8	50	20	V600, V1300

Tube terminals for Ericsson Cables Excel and Fxcel type 10 - 16 mm²

- Data: electrolytic copper, tin plated.
- For PEX-insulated cables 10 mm² Cu solid (Ericsson Excel type) and 16 mm² Cu stranded (Ericsson Fxcel type), to be applied non-tensioned.



Cat. no. mm ² , bolt	mm W	d	N	N ₁	L	Pcs/pack	Crimp die id-no.	Rec. tool
KRX10-8	22	4,5	8,5	17,5	68	3	7	V600, V1300
KRX10-10	22	4,5	11,5	18,5	72	3	7	V600, V1300
KRX10-12	22	4,5	12,5	19,5	74	3	7	V600, V1300
KRX16-8	16	5,5	8,5	17,5	61	3	8,5	V600, V1300
KRX16-10	16	5,5	11,5	18,5	65	3	8,5	V600, V1300
KRX16-12	19	5,5	12,5	19,5	67	3	8,5	V600, V1300

Two crimps are made when using the V600-, V611-, PVL611- or T2600-systems, die TB7-20.

Connectors for Ericsson Cables Excel and Fxcel type 10 - 16 mm²

- Data: electrolytic copper, tin plated.
- For PEX-insulated cables 10 mm² Cu solid (Ericsson Excel type) and 16 mm² Cu stranded (Ericsson Fxcel type), to be applied non-tensioned.



Cat. no. mm ²	mm d	D	L	Pcs/pack	Marking*	Rec. tool
KSX10	4,5	7,0	65	3	10x7	V600, V1300
KSX16	5,5	8,5	65	3	16x8,5	V600, V1300

* Elpress logotype included.

Two plus two crimps are made when using the V600-, V611-, PVL611-, or T2600-Systems, die TB7-20.

For detailed information regarding recommended tool or system, see chapter 6.