

# Industrial Gland Kits Application



## Features & Benefits

- > Indoor/Outdoor for Unarmoured Cable
- > Brass indoor and outdoor cable gland & accessories
- > For circular, unarmoured plastic or rubber sheathed cables
- > Suitable for most climatic conditions, weatherproof and waterproof
- > Kit comprises:
  - A1/A2 Gland
  - Brass locknut
  - PVC shroud
- > 2 per kit size up to and including 25mm

## A1/A2 Brass Gland Kit KM409 Series

### Technical Data

- > EN 50262
- > BS6121:Pt 1:1989
- > Gland rated to IP66 with use of suitable sealing washer or thread sealant at gland interface
- > Service temperature -20°C to +90°C
- > CuZn39Pb3 extruded brass alloy used for guaranteed strength and performance

### Gland Details

Cable Dimensions mm		Size	Kit Reference		Gland Dimensions mm				
Overall Diameter A			Design Number	Items Per Kit	Entry Thread		Approx. Length from Shoulder D mm	Hexagon Size	
Min	Max				Size B	Length C		Across Flats E	Across Corners F
3.5	8.5	20SS	KM409-71	2	M20×1.5	10	20	22.0	24.9
8.0	11.5	20S	KM409-52	2	M20×1.5	10	22	22.0	24.9
11.0	13.5	20	KM409-53	2	M20×1.5	10	22	24.0	26.8
13.0	19.5	25	KM409-55	2	M25×1.5	10	25	30.5	34.0
19.0	25.5	32	KM409-56	1	M32×1.5	10	25	42.4	48.0
25.0	32.0	40	KM409-57	1	M40×1.5	15	33	47.2	53.6
31.5	37.0	50S	KM409-58	1	M50×1.5	15	30	55.0	60.0
36.5	43.0	50	KM409-59	1	M50×1.5	15	30	56.4	61.5
42.5	50.0	63S	KM409-60	1	M63×1.5	15	34	70.1	77.2
49.5	55.0	63	KM409-61	1	M63×1.5	15	32	75.0	83.0
54.5	61.0	75S	KM409-62	1	M75×1.5	15	32	80.0	87.4
60.5	67.0	75	KM409-63	1	M75×1.5	15	40	85.0	95.0

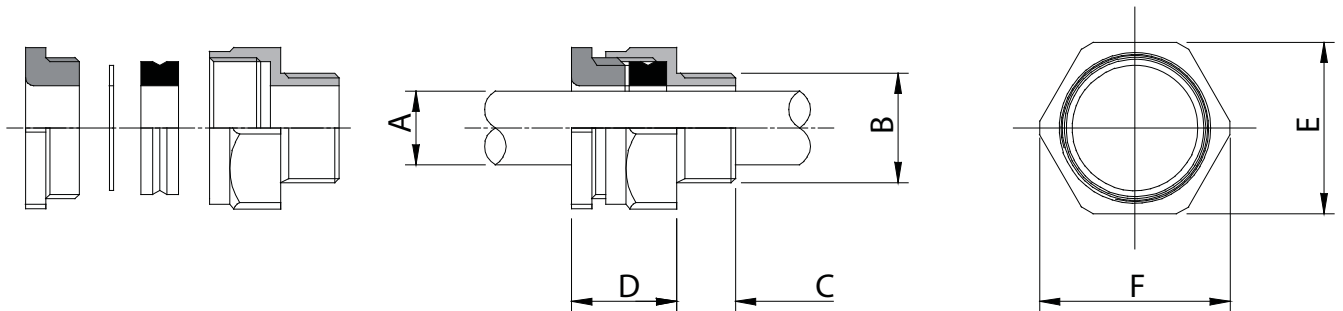

Make the right connection...

